

# SOLAR WAX MELTER

## DETAILS FOR 3/4" LUMBER

A melter of this size will handle wax rendering from 60 hives. You can modify the dimensions and design to fit your own needs. Melters come in all shapes and sizes and can be made out of just about any used material. The sheet metal pan should be 4" to 6" deep and big enough to accept excluders or at least 2 full-depth frames. Paint the entire unit black for max. heat absorption. You should put a coarse screen across the outlet of the pan to keep debris from getting into the pan of molten wax. Make a cappings basket out of "expanded" metal (wire lath) that will fit into the sheet metal pan.

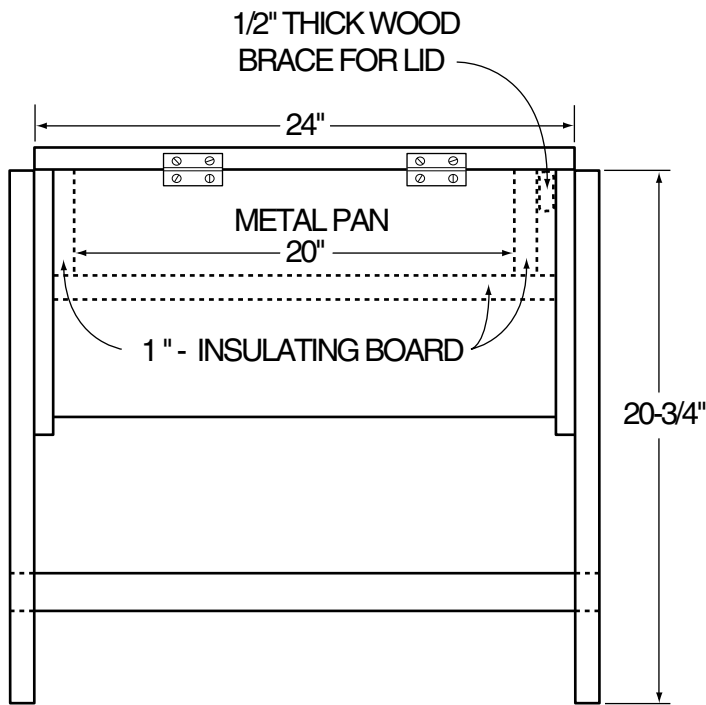

**BACK VIEW**

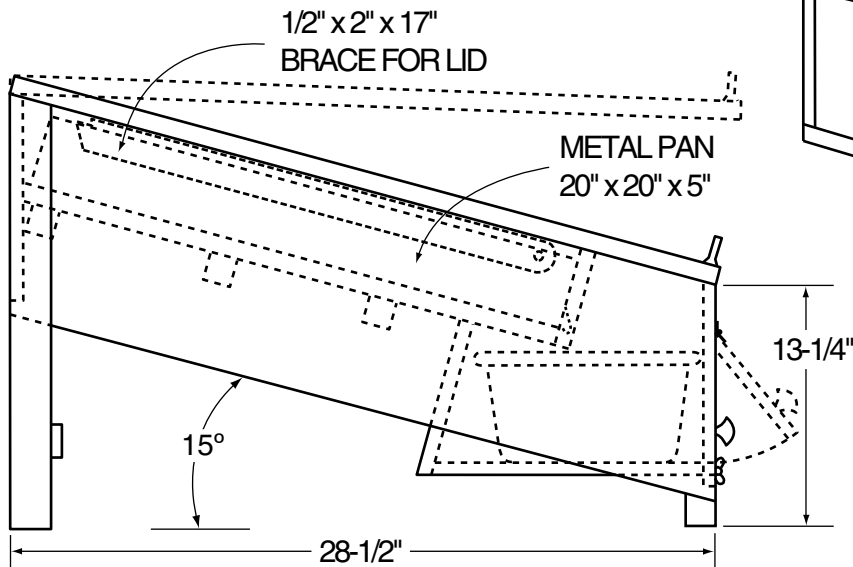
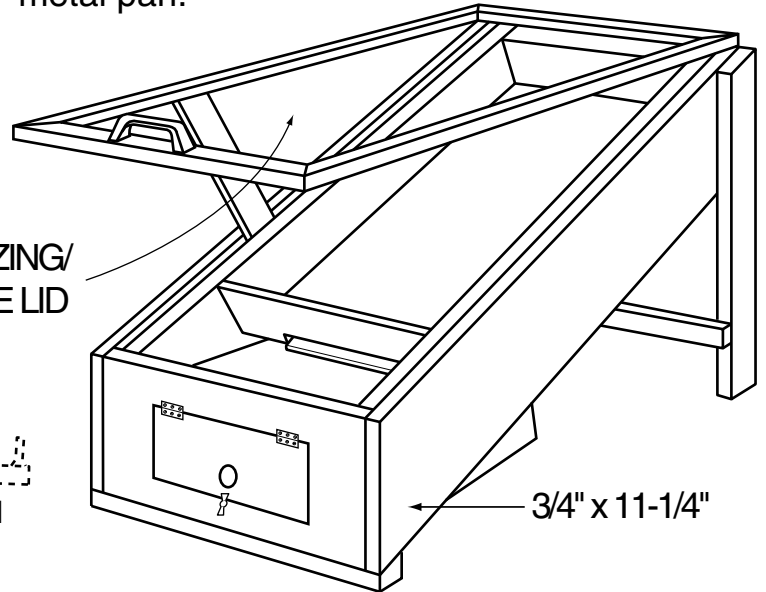

**SIDE VIEW**

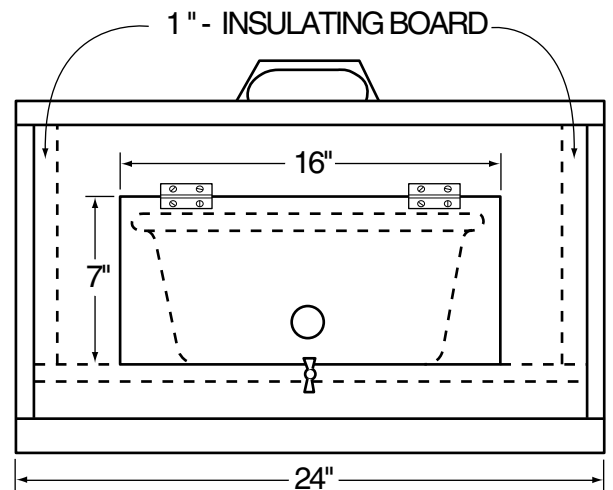

**FRONT VIEW**